



ActionPlas
GROUP

CASE
STUDY:
5S
SOLUTIONS

Creating
to inspire

0113 255 3355
www.actionplas.com

ActionPlas GROUP

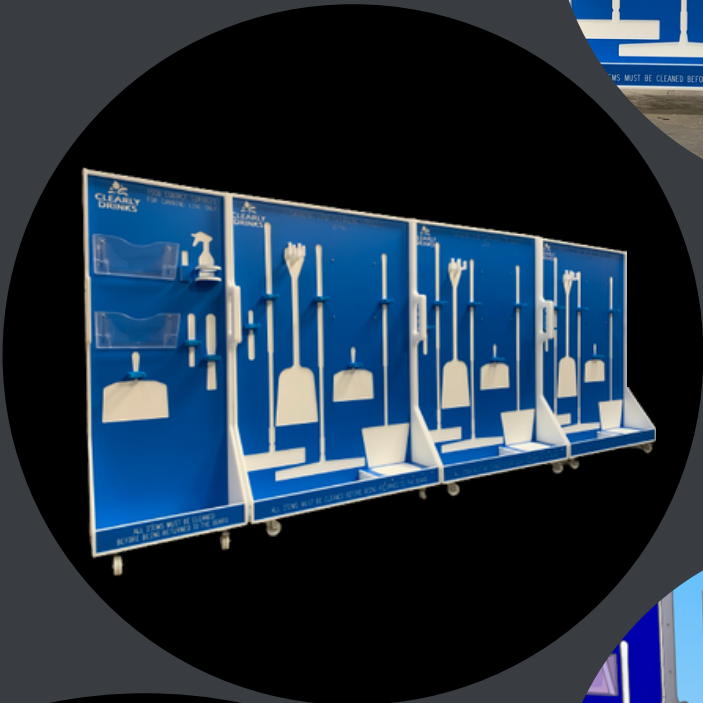

PROJECT REQUIREMENTS

- ① Create 4 new Hygiene Boards to reflect the new canning line facility
- ① Utensils to be easily removed and returned
- ① Mobile, durable and appropriate for the working environment
- ① Titles on the boards to reflect line location
- ① Help implement 5S Standard

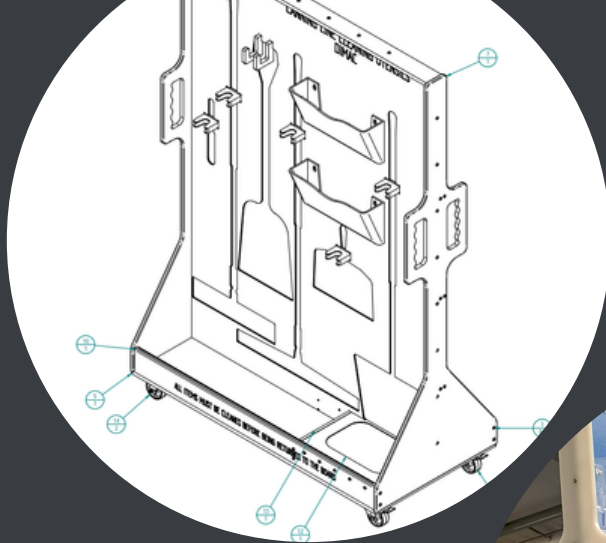

“

Thank you so much,
these look absolutely
great!



APPROACH & SOLUTION

Once we had clarity on the customers requirements we made note of dimensions and took all the tools the board needed to house off site to be measured in by our Design Engineers. Concepts were then sent to the client for comment/ approval.

After a revision to the concept the client signed off on the drawing and production commenced.

We manufactured the 4 trolleys out of 19mm Play-Tec to create the shadows and keep the rigidity . We routed out the shadows for the tools adding hangers to fix the brush, dustpan shovel, and brushes. We left screws in to fix the document wallets on, we added the frame and wheels and ergonomically designed handles before completion. The job was delivered on time, which was a few days before production started ensuring there was no down time.



Subcontracts 

Projects 

On-site Services 

Additive Manufacturing 